

# J/24 Tuning Guide

---

 [northsails.com/sailing/en/resources/j24-tuning-guide-newport](https://northsails.com/sailing/en/resources/j24-tuning-guide-newport)

North Sails RESOURCES

**Last Updated:** July 18, 2019

**Download North Sails J/24 Quick Tuning Matrix:** [Loos Gauge PRO PT2](#) | [Loos Gauge PRO Model B](#)

Thanks very much for purchasing your J/24 sails from North Sails! We appreciate your business. This tuning guide will help you set up your boat for your new sails. If you have any questions along the way, please give us a call or send us an email. We are always ready to help you and your crew to get the most out of your new sails. Also, we have posted many J/24 related articles on the [North Sails website](#) that will help improve your understanding of this great boat.

This tuning setup is designed to be as “all purpose” as possible. Like many one designs, the J/24 uses just a few sails to cover a wide range of wind and sea conditions. Set your boat up the way we have described here, and you will have great speed in all conditions.

## WITH THE MAST DOWN

---

- Measure the length of your spreaders from the side of the mast to the point where the shrouds touch the end of the spreaders. The spreaders should be as short as possible, 760 mm.
- Make sure the spreaders are swept back the same amount on each side:
  - Tie a small string tightly between the shrouds just above the spreaders
  - Set the mast on sawhorses, track facing up, with the mast butt (plug in place) resting on a horse.
  - Using the back edge of the mast shoe as your guide, check to see the string between the shrouds and aft edge of the mast shoe are parallel. (See picture #1)

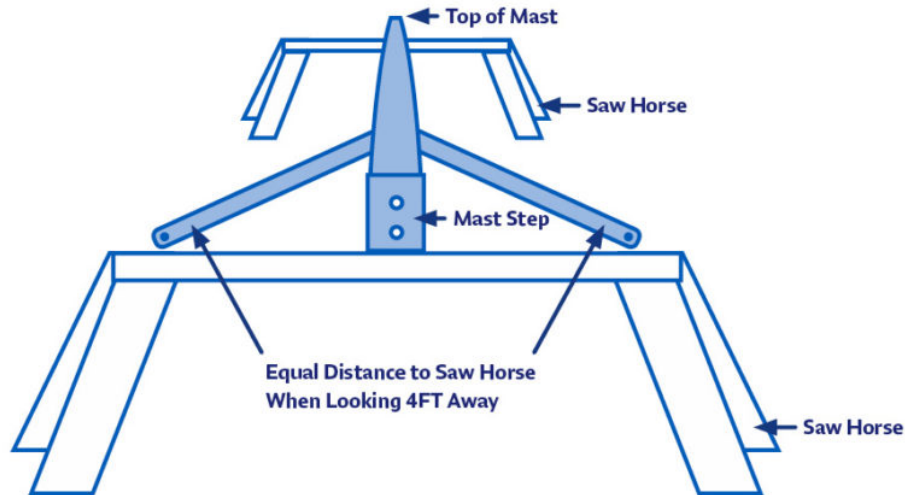

Picture 1 – If not parallel you will need to take the spreaders off and slide the thru bar in your mast to one side or the other to compensate. If you do not have a thru bar either file down the stubby male fittings or use spreader adjusters to make the sweep the same on each side.

- Now check the deflection of the spreaders. This is the distance between the taut string and the aft side of the mast. For the Fathead main this should be 160-165 mm.
- If your mast has not been shortened before, measure down the mast from the forestay fixing point as described in the class rule 3.5.2 (7725mm down from headstay pin center). You will need this mark later to find out if your mast can be shortened. You want your mast as short as possible.
- The headstay should be as long as possible. To check this, attach the headstay and hold it alongside the front of the mast and make a mark on the headstay corresponding with the mark in Rule 3.5.2 (7725mm down from headstay pin center).

## WITH THE MAST UP

---

Have a class measurer with an approved jig inspect your mast to make sure it is as short as possible. The mark you previously made on the mast must be no lower than 400mm above the sheerline. We like to cut our mast so the lower edge of the band is 405 mm above the sheerline to ensure that our mast will always measure in. See picture #2.

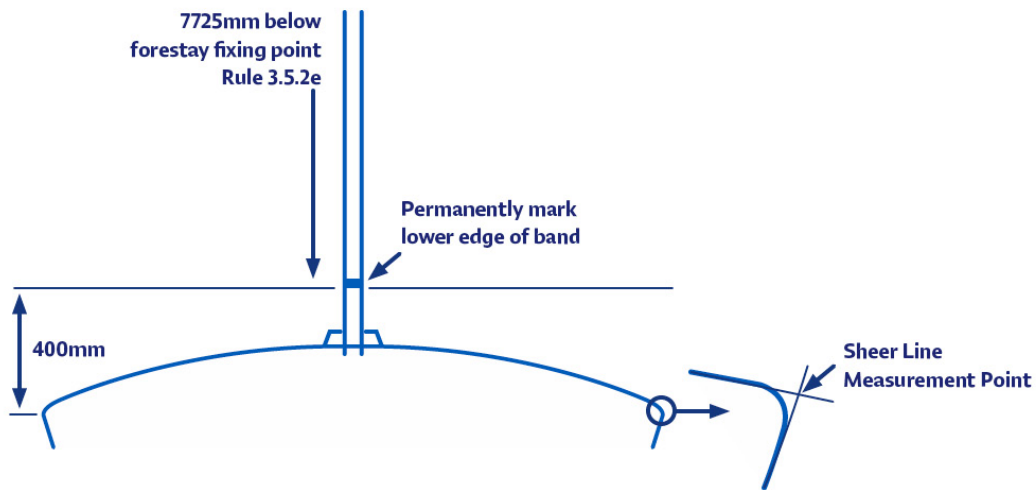

Picture 2

- Step the mast and attach all shrouds very loosely (except the backstay) leaving any mast blocks out for the moment. Temporarily hold the mast butt in place on the “I” beam with a pair of vise grip pliers.
- Make sure that the mast is positioned as far aft at deck level as possible. Have a friend hold the end of your tape at the stem measurement point and measure again straight to the lower edge to the mast band. We want this measurement to be as close to maximum as possible, 2925mm. Chock the mast at the deck to hold it in this position. See picture #2 above for determining measurement point at stem.
- The next step is to place the butt of the mast in the proper position on the “I” beam down below.

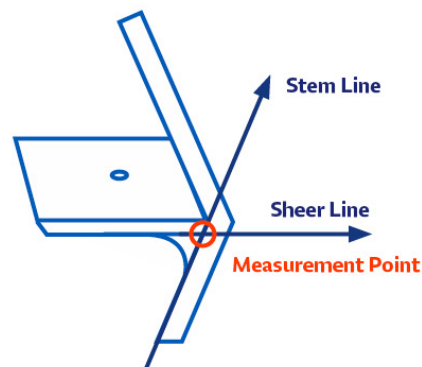

Rule 3.5.3b(2) and 3.5.3c

Picture 3

Using a friend to hold the end of the tape, measure from the top of the third bolt holding the stem fitting on (inside the boat, up in the bow) to the intersection of the front of the mast and the shoe that rides on the “I” beam. This measurement should be 112.5”.

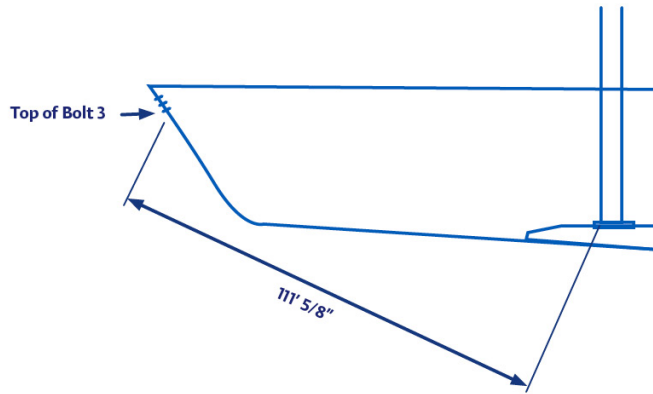

Hold the mast butt in place at this position temporarily with a pair of vise grips.

- Now tighten the upper shrouds to 20 and the lowers to 15 on a Loos Model B tension gauge. Snug the uppers first and then, using the genoa halyard, measure down to the chainplates on both sides to be sure the mast is centered in the boat. Sight up the backside of the mast to be sure it is straight.
- Now we will check to make sure the mast butt is in the right place. With the backstay connected (but very,very loose) measure the tension on the headstay. The tip of your gauge should be about 40-50 mm from the close side of the headstay wire. See picture #4 below. (Note: We typically use an older, separate Loos Gauge B for the headstay measurement to keep the new one in good condition!)

If your headstay is tighter than this, you will need to move your butt aft slightly; if it is looser, move it forward slightly. **After moving the butt, check and adjust the tension on the shrouds before you recheck the headstay tension.**

This should set up your mast with 2 – 2.25” of prebend. To verify, hold the taut main halyard at the gooseneck and sight up the back side of your mast. If you see something different, recheck your measurements.

## TUNING CHART

The J/24 has just 4 sails to cover the entire wind range for racing. For the best performance in each condition, we adjust shroud tension depending on wind speed. As the final step in setting up your boat, fill in the attached tuning chart with how many turns of the turnbuckles it take to get from one setting to another. We often adjust our shroud tensions between races (it is against class rules to do so while racing), and it is impossible to get accurate tension gauge readings while the sails are up if there are any waves at all.

NEW LOOS GAUGE PRO MODEL PT-2				
Wind Speed (Knots)	Uppers Tension	Uppers (Turns from Base)	Lower Tension	Lower (Turns from Base)
0-5	13	-1	9	-1
5-8 – BASE	15	BASE	12	BASE

<b>8-10</b>	17	1	13	0.5
<b>10-12</b>	18	0.5	15	0.5
<b>12-14</b>	22	1.5	18	0.5
<b>14-16</b>	24	1.5	22	1
<b>16+</b>	26	0	26	1.5

<b>OLD LOOS GAUGE PRO MODEL B</b>				
<b>Wind Speed (Knots)</b>	<b>Uppers Tension</b>	<b>Uppers (Turns from Base)</b>	<b>Lower Tension</b>	<b>Lower (Turns from Base)</b>
<b>0-5</b>	18	-1	10	-1
<b>5-8 – BASE</b>	20	BASE	15	BASE
<b>8-10</b>	23	1	18	0.5
<b>10-12</b>	24	0.5	21	0.5
<b>12-14</b>	27	1.5	24	0.5
<b>14-16</b>	29	1.5	27	1
<b>16+</b>	29	0	31	1.5

Special note on the backstay: Adjusting the tension of your shrouds changes backstay tension too. Each time you tighten or loosen your shrouds, be sure to tighten or loosen the two smaller backstay turnbuckles too, so that the blocks riding on the backstay bridles stay 6-8” below the “y’ in the backstay when the adjustment line is slack. This is very important to make sure the headstay can get tight and loose enough depending on conditions. (We typically adjust 6 turns on each backstay leg between settings.)

**You are now ready to start sailing!**

## **SAIL TRIM**

---

Follow these guidelines to set up and trim your sails.

### **Mainsail**

---

#### **Outhaul**

- 0-4 knots: Clew should be 1/2 “ from black band
- 4+ knots: Clew should be at band

### **Cunningham**

No cunningham until about 12 knots, then tension until wrinkles in luff are just removed.

## **Vang**

Upwind, keep loose to 8 knots. 8-15 knots, tension to remove all slack. Above 15 knots, tension very hard so boom does not rise at all when the mainsheet is eased.

Downwind, tension so top batten is parallel to boom.

## **Traveler**

Keep all the way to windward until entire crew is sitting on weather side with legs out. As soon as crew is on the weather rail with legs over, drop down 6". After that, use it to keep the boat flat by letting it down until the leeward edge of the car is in the middle of the track. If you have to drop below midline to keep the boat flat, pull on more backstay. We do not like to sail with the traveler to leeward of midline.

## **Backstay**

Use to control fullness on main and genoa. Leave loose until about 8 knots. Slowly tighten as breeze builds to depower boat. At its tightest, the blocks will be all the way down to the top of the pushpit. A small adjustment (1-2") can have a big effect. Be sure to adjust the backstay turnbuckles with the shrouds.

## **Mainsheet**

Up to 10 knots of wind, tension the mainsheet so the top batten is parallel to the boom and the top tell tale is flying 50-60% of the time. In more than 10 knots, the top tell tale should be flying all the time, because the top of the main will be flatter.

## **Genoa**

---

Trimming the genoa involves three major adjustments: lead position, halyard tension, and sheet tension.

### **Halyard Tension**

Set the halyard so the luff of the genoa has just a hint of wrinkles. We have found that it is much better to have the halyard too loose than too tight. In light air, make sure that the luff is nice and loose. As the wind builds, tension the halyard to smooth out the luff

It is important to have a few marks on your genoa halyard near the cleats or stopper to duplicate fast settings for a range of conditions. We mark off 1/2" increments on the line.

### **Lead Position**

It is important to drill two extra holes between each of the factory-drilled holes in your genoa track. The standard spacing is too far apart to be workable.

Having the lead in the correct position is critical for good speed. In moderate breeze (4-8 knots), trim the sail in and position the lead car so that the sail touches the spreader and the chainplates or turnbuckles at exactly the same time. Mark this position. This will be your neutral point for your jib lead.

## Sheet Tension

We check the sheet tension by judging how many inches the sail is trimmed away from the end of the spreader. Generally we never trim the sail tighter than 1" from the end of the spreader.

MAINSAIL SETTING CHART				
Wind Speed (Knots)	Traveler	Backstay	Topp Batten Angle	Outhaul
0-6	All way up	None	Closed 3 degrees	In 1/2"
7-12	Down 3-4"	1/4 on	Closed 3 degrees to parallel	In 1/2"
12-18	Middle	1/2 to 3/4 on	Parallel to open 3 degrees	In 1/2"
18+	Below CL 2-3"	Max on	Open 3-6 degrees	In 1/2"

GENOA SETTING CHART			
Condition	Lead	Halyard	Sheet
<b>0-6 Flat</b>	1 aft of neutral	Wrinkles	3-4" off spreader
<b>0-6 Choppy</b>	On Neutral	Wrinkles	3-6" off spreader
<b>7-13 Flat</b>	On Neutral	Just smooth	2-3" off spreader
<b>7-13 Choppy</b>	1-2 holes forward	Wrinkles	2-4" off spreader
<b>14-18 Choppy</b>	1-2 holes forward	Smooth	4-6" off spreader
<b>18+ Choppy</b>	On Neutral	Tight	6-8" off spreader

Change your settings depending on the condition. As the wind builds and dies, you should be constantly adjusting the genoa sheet.

## Class Jib

For fine-tuning the lead position, drill two extra holes between each set of factory holes in the jib track. Start with the jib lead block even with the chainplates and fine tune the lead position from there.

Unlike the genoa, the luff of the jib should always be smooth. In moderately heavy air, you can get the luff too tight. The luff of the sail should break evenly up and down. If the sail breaks high first, move the lead forward; if it breaks low first, move the lead back. Check this carefully and make a mark on the deck in the correct spot.

Sheet tension is critical. We like to adjust the tension on the jib sheet to balance out the helm. If the boat has a bit of weather helm, trim the jib slightly to pull the bow down. If the boat has leeward helm, ease the jib slightly. Because it's a high aspect sail, you only need to change the tension on the sheet a small amount (1/2" increments) to have a significant effect.

## **Spinnaker**

The spinnaker should be at full hoist at all times. The general rule of trim is to allow 2-4" (50-102 mm) of curl in the luff of the sail. Set the outboard end of the pole at the same height as the free floating clew of the sail, and pull back on the guy until the pole is perpendicular to the apparent wind. Use the upper pole ring for most conditions. If you are going slow, try raising the pole a couple of inches.

### **Downwind — Light air**

Concentrate on good communication between helmsman and spinnaker trimmer. The goal is to sail as low as possible, while still maintaining good pressure in the spinnaker (measured by tension on the sheet). Try not to sail too high and add distance, but do not sail too low at a slow pace. Be careful not to pull the pole too far aft because it flattens the spinnaker.

### **Downwind — Heavy air**

Don't square the pole back too far as this makes it easier for the spinnaker to roll out to weather. Do not let the clew of the spinnaker go past the headstay. To sail low without rolling to weather, keep most of the crew hiked to leeward.

### **Downwind Tips**

Pole height is important and changes in increments of 1" (25 mm) have a big effect on the spinnaker. The luff of the sail should curl evenly from top to bottom. If the spinnaker breaks high, raise the pole. If the break is too low, lower the pole.

Whether or not you use tweakers (or twings), it's crucial to have a foreguy system that locks the pole in place. Every up and down or back and forth motion of the pole (and hence the spinnaker) is energy that will not be pulling the boat forward.

An efficient system for launching and retrieving the spinnaker is another must. We recommend a deep cockpit launching bag. Call us if you would like one made for your J/24.

In conclusion:



- Always sail the boat as flat as possible, except in very light air
- Sail as close to the max crew weight limit (400 kg) as possible.
- Do not be afraid to change settings if you are slow.
- Set up a tuning chart and use it.
- Have open positive communication on board.
- Sail fast and have fun!

## **SAIL CARE**

---

Your North Sails are constructed out of the best materials on the market today. We make sure of this by testing every roll of cloth we use. Through proper care and maintenance, your sails will give you the performance you have come to expect.

The most important factor for long sail life is to watch for signs of wear and tear in high load and chafe areas. Be sure to wash the sails off with fresh water, and dry the sails thoroughly before storing. A dry, mild climate is best. Excessive heat can cause problems with the sails due to the possibility of shrinkage. It is best to roll the mainsail, genoa, and jib.

### **Mainsail**

---

When hoisting and lowering the sail, try to minimize the amount of creasing or wrinkling of the sail. Every time the sail gains a crease, the cloth breaks down that much faster. Always have someone control the leech and luff during these procedures.

The battens can be left in the sail without any problems. Be sure to roll the sail down the leech so that the battens will not twist, which could damage them.

### **Genoa**

---

With today's Mylars becoming softer, rolling the genoa has become more difficult. When folding, creasing can develop along folds and accelerate the breaking down of the Mylar. The worst case scenario is for the sail to be rolled and then folded.

### **Jib**

---

When rolling the jib, keep the battens perpendicular to the leech. Pay special attention to the battens and batten pockets for wear and tear. Since this sail is manufactured from yarn-tempered Dacron, problems can arise due to mishandling.

### **Spinnaker**

---

Caring for the spinnaker is fairly straightforward. Be sure to repair all tears and pulled stitches as soon as possible. Store the sail folded.

This tuning guide only begins to cover all there is to know about racing the J/24, so North Sails J/24 experts have prepared a professional, in-depth J/24 racing clinic to help you and your fleet improve. In the course of an evening or weekend, you will learn more about

racing your J/24 than you could possibly learn in a season of racing on your own. For more details, please call a North Sails J/24 expert!

At North Sails, we are constantly striving to make our products better. If you have any comments on this tuning guide, we'd love to hear from you. Please give us a call or send us an email.